

TWO GB 142 Wiring with DHW on System Side of a Hydro Separator

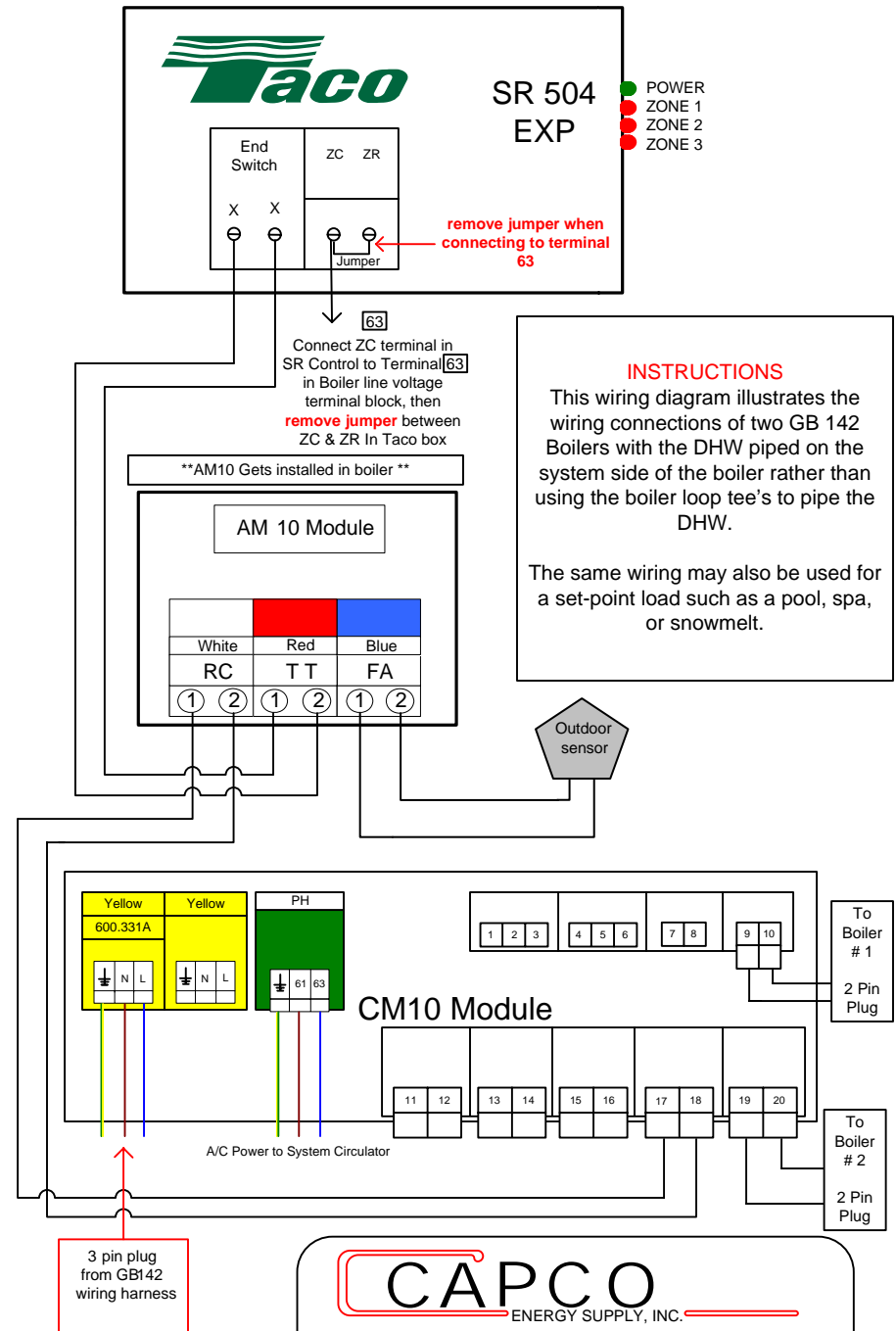
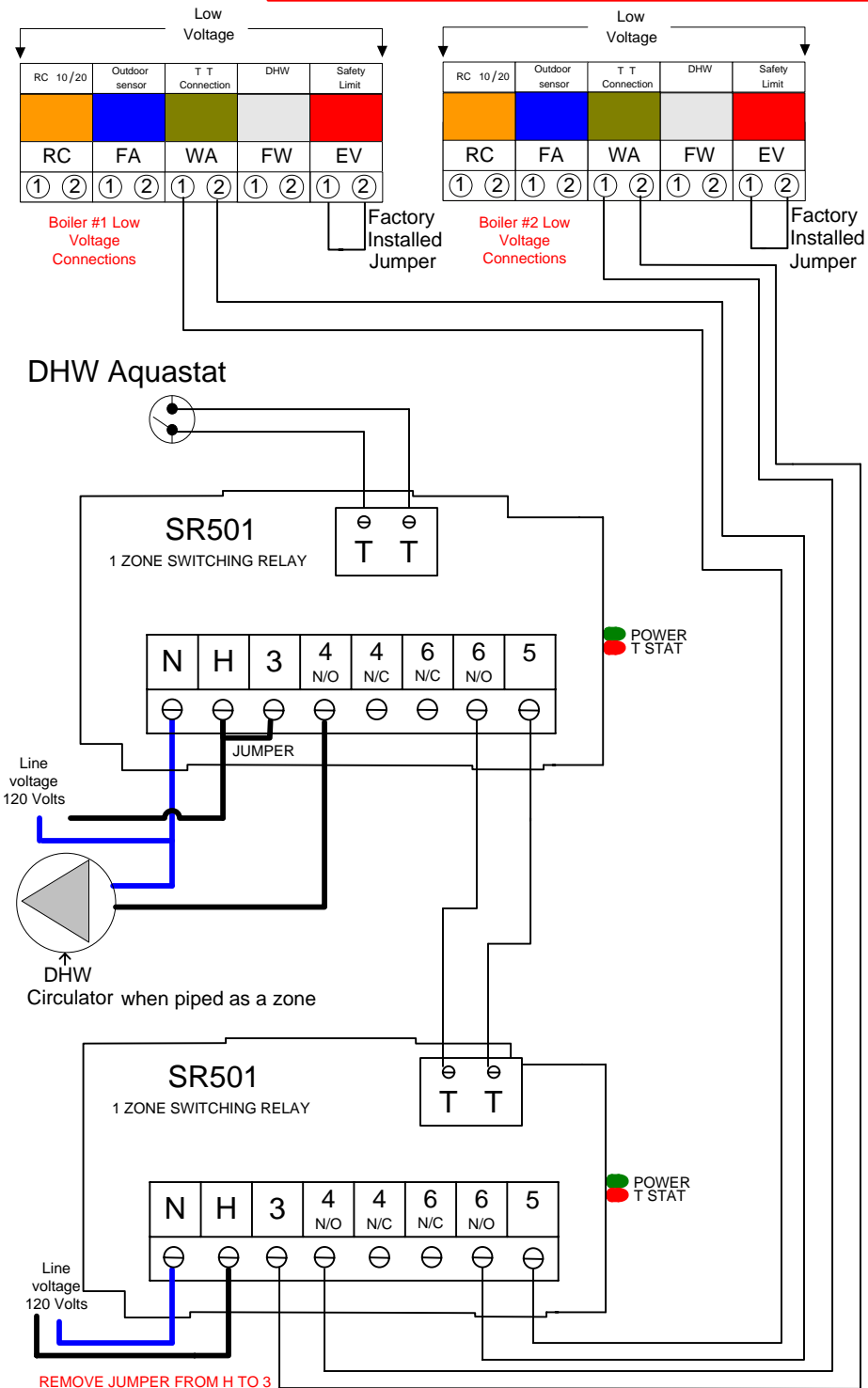

INSTRUCTIONS

This wiring diagram illustrates the wiring connections of two GB 142 Boilers with the DHW piped on the system side of the boiler rather than using the boiler loop tee's to pipe the DHW.

The same wiring may also be used for a set-point load such as a pool, spa, or snowmelt.

CAPCO
ENERGY SUPPLY, INC.

781-721-0303 FAX 781-721-9119 WWW.CAPCOSUPPLY.COM

10 INDUSTRIAL PARKWAY WOBURN MA 01801	GB142 With AM10, SR Pump Relays and DHW off of System side of Hydro-Separator	Michael Fox 09/06/2006
------------------------------------------	-------------------------------------------------------------------------------------	---------------------------

THIS IS ONLY A CONCEPT DRAWING. ALL CONDITIONS AND NECESSARY COMPONENTS MUST BE FIELD VERIFIED AND ARE THE RESPONSIBILITY OF THE INSTALLING CONTRACTOR